

**TightWat<sup>2</sup>**  
*Save energy. Save money.*

***User's Guide***

*(Rev. B)*



Inside Front Cover

## ***Table of Contents***

I. Cautions / Warnings	2
II. Timer installation	3
III. Understanding TightWatt2 Cycles	8
IV. Quick Set-Up Steps	9
V. Manual Operation	11
VI. Troubleshooting / Cleaning	12
Warranty	Back Cover

© 2007 Allen Concepts, Inc.

Last revised: 03/31/2008

## ***I Cautions & Warnings***

**IMPORTANT: READ IMMEDIATELY!**

In order for your timer to function normally, it must be released from the in-store demo mode. With the 9V battery back-up installed or connected to power, simultaneously press and hold both buttons for 5 seconds. Do not perform this procedure unless the front cover is in place and there is no risk of electrical shock.



**DANGER – ELECTRICAL SHOCK HAZARD**

Failure to follow instructions may result in personal injury and/or death.

Read and understand instructions before installation. Retain these instructions.

The jack underneath the battery cover is for TightWatt brand accessories only.

Plugging anything else into this jack will void the warranty and may damage the device.

**ATTENTION: READ CAREFULLY BEFORE ATTEMPTING TO INSTALL YOUR TIGHTWATT®2 ENERGY-SAVING TIMER. FAILURE TO COMPLY COULD RESULT IN PERSONAL INJURY AND/OR PROPERTY DAMAGE! RETAIN FOR FUTURE REFERENCE.**

Thank you for purchasing a TightWatt®2 energy-saving timer. This timer has been specifically designed to keep your pool looking beautiful year-round, while using a minimum amount of electricity. Our patent-pending technology automatically varies your filter run-time with the seasons – to save you money! By using less energy, you're also helping the environment.

### **General Safety Information:**

**WARNING:** Disconnect all power before installing or servicing this timer or its connected loads.

1. Follow all local electrical and safety codes, National Electrical Code (NEC), as well as Occupational Safety and Health Act (OSHA).
2. If the power disconnect point is out of sight, lock it in the “OFF” position and tag it to prevent unexpected application of power.
3. The timer case must be grounded if a metal case is used.
4. Do not exceed the maximum current carrying capacity of this time switch.
5. Always replace the top cover and Plexiglass® insulator before turning power “ON”.

6. If the equipment is used in a manner not specified by the manufacturer, the protection provided by the equipment may be impaired.

The TightWatt timer contains a safety feature which allows the relays to remain in an open state. This is useful for situations when you want to be sure that the pump motor will not turn on automatically. To open the relays, press both buttons on the front panel at the same time, and “Relays Open” should appear on the screen (see image at left). As long as this message is on the display, the relays will be in an open state. Automatic cycles will not begin while the timer is in the “Relays Open” state. Press any button to return to the normal mode of operation.



The “Relays Open” mode will open the relays. However, the line connections are still energized, and load connections may be energized dependent upon the wiring configuration. “Relays Open” is intended as a method to force the pump to an off state, it is by no means a guarantee that circuits are not energized.

## II Installation

**WARNING: This product must be installed in an adequate enclosure, suitable for the end-use environment. An adequate enclosure must be provided if the device is provided without one.** A) A switch or circuit-breaker shall be included in the building installations;

B) it shall be in close proximity to the equipment and within easy reach of the OPERATOR; C) it shall be marked as the disconnecting device for the equipment. DISCONNECT THE POWER TO THE TIMER AND THE LOADS BEFORE INSTALLING.



The TightWatt timer has been designed to meet the following environmental conditions: Pollution degree 2; Installation Category II; Altitude 2000m; Humidity 5-95% non-condensing; Temperature 0 degrees C to 40 degrees C.

Electrical Ratings for Model # TW2-PFC (Rev. B)		
Input Rating	Power Consumption	Load Rating
100-240V AC 50/60 Hz +/- 10%	7 Watts maximum	<b>Main Pump High:</b> 100-240V AC Respectively, 50/60 Hz, 15A, 2 HP <b>Main Pump Low:</b> 100-240V AC Respectively, 50/60 Hz, 15A, 2 HP <b>Auxiliary Pump:</b> 100-240V AC Respectively, 50/60 Hz, 15A, 2 HP



### Installation:

1. Mounting the enclosure. If the enclosure is already mounted, proceed to step 2. Mount the timer in the desired location using the mounting holes provided. Mount timer at eye level, if possible, providing room left of the enclosure for the cover to swing open fully.

2. Enclosure access should be controlled. It is recommended that it be locked and not be accessible by children.

3. If desired, install the 9V battery back-up at this time. This will allow the clock to maintain the correct time and date should a loss of power occur. Replace the 9V battery back-up cover after installing the battery.

4. Installing the timer in the enclosure. Slide the timer into the enclosure with the top of the timer tilted slightly forward. After it comes to rest on the guides, push the top back so that it latches on the spring latch (see images to the left).

5. Remove the top cover of the timer by removing the two screws which affix it to the base.

6. Strip the supply and load wires by removing 1/2 inch of insulation. DO NOT USE ALUMINUM WIRE. Insert the wire ends under the proper terminal plates and tighten the screws firmly. Ensure that supply and load wires are sized according to local electrical codes, National Electrical Code (NEC), and Canadian Electrical Code (CEC).

Wiring Table for Model TW2-PFC (Rev. B)		
Terminal #	Name	Description
1	Line 1	circuit breaker for primary pump
2	Load 1	primary pump high speed winding /common
3	Line 2	circuit breaker for primary pump
4	Neutral/Load 2	primary pump high speed winding
5	Load 1	primary pump low speed winding (optional)
6	No Connect	
7	Line 1	circuit breaker for auxiliary pump
8	Load 1	auxiliary pump
9	Neutral/Line 2	circuit breaker for auxiliary pump
10	Neutral/Load 2	auxiliary pump

7. Instructions for protecting earthing. The load ground must be connected to the incoming power ground to prevent a shock hazard in the connected load (in the event of a fault). All grounding wires must be sized according to the applicable electrical codes in order to handle the fault current. If using a metal enclosure, be sure that the enclosure itself is grounded.

8. Push wires toward the back of enclosure, so they will not interfere with the installation of the Plexiglass® insulator (see images below).

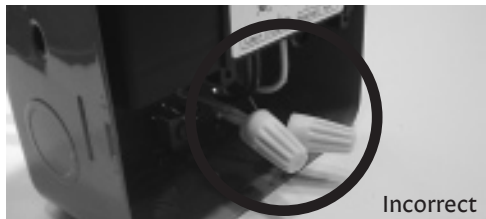

9. If using a smaller sized enclosure, it will be necessary to snap the Plexiglass® insulator along the scratch line for proper fit. With safety glasses on, simply place the line along a table edge, hold firmly in place and apply pressure to the overhanging section of Plexiglass® until it snaps apart (see images below).



10. Attach the Plexiglass® insulator to the TightWatt unit using the screw provided.

11. After the TightWatt timer is installed, with the 9V battery cover in place, and Plexiglass® insulator in place, apply power to the timer by turning on the circuit breaker.

TightWatt2 Two-Speed Timer >  
(Rev. B)

**TightWatt2 240V Wiring Diagram**

Circuit Breaker Panel

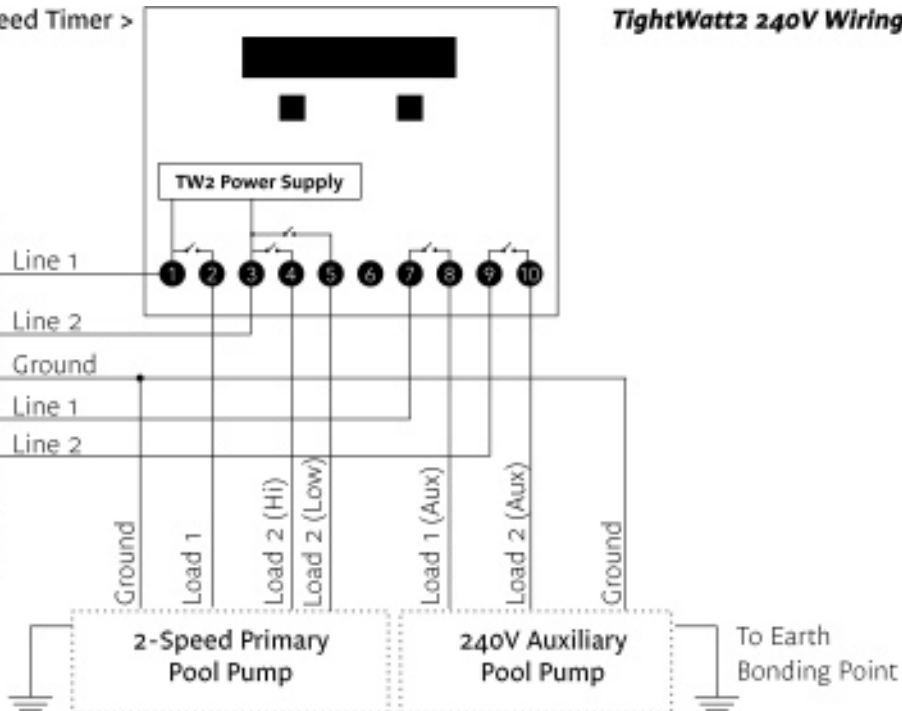
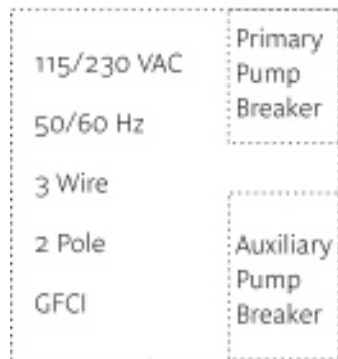

TightWatt2 Two-Speed Timer >  
(Rev. B)

**TightWatt2 120V Wiring Diagram**

Circuit Breaker Panel

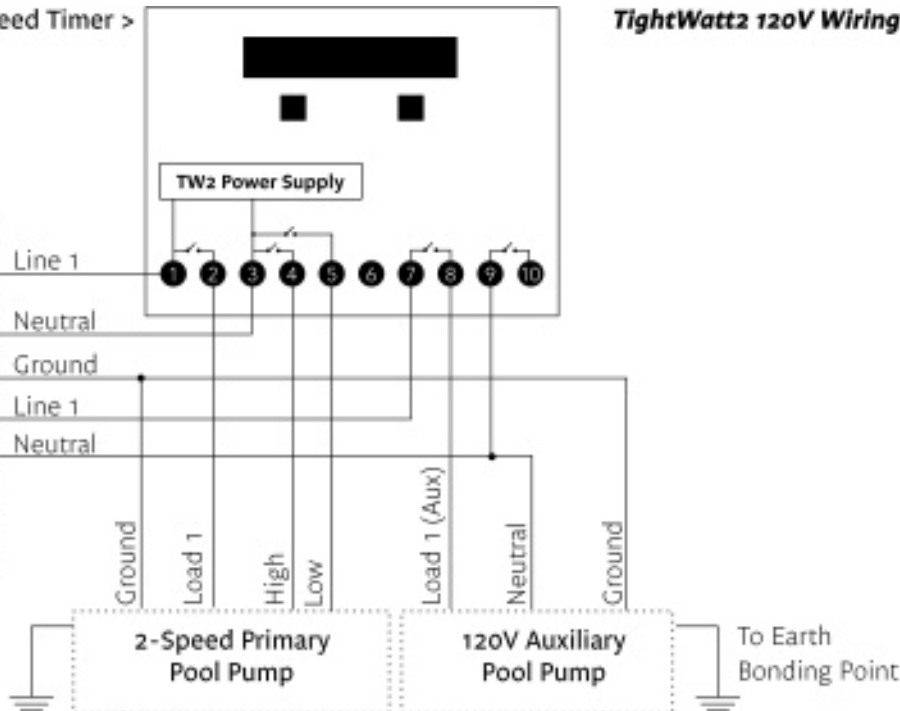
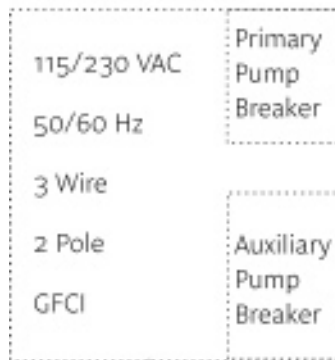



off 10 minutes before the high-speed primary pump shuts off. If the duration of the high-speed cycle is less than 20 minutes, the heater will not turn on at all.

### Mode selection:

With the display in its normal mode (time and date displayed), press both buttons at the same time. You should see the following:

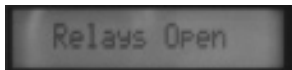

Next, press and hold the “Set/Enter” button.

After five seconds, the mode selection menu will appear: **Mode: standard**

Press the “Change” button to toggle between the “standard” and “fireman” modes. Press “Enter” when you have made your selection.

### ***IV Quick Set-Up Steps for Standard Operation: Setting your year-long run schedule.***



**Step 1 |** Set the current time: Press the “Set” button. Display will resemble image at left. Use the “Change” button to change the blinking value and the “Enter” button to advance to the next field. Use this procedure to set the current time.

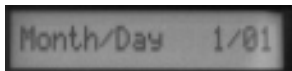

**Step 2 |** Setting the current date: After the current time has been set, the display will resemble image at left. Use the “Change” and “Enter” buttons to set the current date.



**Step 3 |** Set the number of cycles per day: Use the “Change” and “Enter” buttons to select how many filter cycles you want to run per day (maximum of 2).



**Step 4a |** Set the 1st start time: This is the time your pump will turn on each day. A full pump cycle will run each day beginning at the designated start time.

**Step 4b** | Set the 2nd start time (optional): This is the time your pump will run the second daily cycle (if 2 start-times were selected in option 3). A full pump cycle will run at each of the designated start times.



**Step 5** | Setting the summer high run time: After your start time(s) have been set, you'll be prompted to set your "Summer Hi" run time. This is the amount of time that the primary pump will run on high-speed mode at the beginning of each cycle during the summer months.



**Step 6** | Setting the summer low run time: After the "Summer Hi" has been set, you'll be prompted to set your "Summer Low" run time. This is the amount of time that the primary pump will run on low-speed during the summer months. The low-speed will run after the high-speed portion of the cycle is complete. Set this value to 0:00 if you do not have a two-speed primary pump.



**Step 7** | Setting the winter high run time: After the "Summer Low" has been set, you'll be prompted to set your "Winter Hi" run time. This is the amount of time that the primary pump will run on high-speed mode at the beginning of each cycle during the cold winter months.

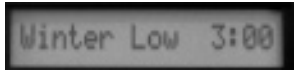

**Step 8** | Setting the winter low run time: After the "Winter Hi" has been set, you'll be prompted to set your "Winter Low" run time. This is the amount of time that the primary pump will run on low-speed during the winter months. The low-speed will run after the high-speed portion of the cycle is complete. If you set the "Summer Low" run time to 0:00, this menu option will not appear.

Skip Step 9 if you have placed the device in "fireman" mode.

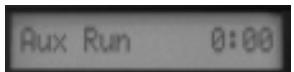

**Step 9** | Setting the auxiliary pump run time: Select the amount of time that you would like your auxiliary pump to run each day. This run time will stay fixed throughout the year, so there is no need for a "summer" and "winter" setting. The auxiliary pump will begin running at the beginning of a cycle. Set this value to 0:00 if you do not have an auxiliary pump.

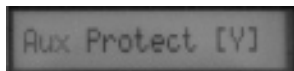

**Step 10** | Auxiliary Protect (Aux Protect) is a feature designed to prevent damage to booster pumps. Selecting [Y] will cause a 2-minute delay between the primary pump turning on and the auxiliary pump turning on. The booster pump will not run unless the primary pump is running. Selecting [N] will disable the protection, and will cause the auxiliary pump to run with no dependencies on the primary pump.

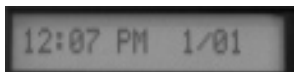

**Set-up complete:** After the 'Auxiliary Protect' has been set, this display will show the current time and date, and the colon between the hours and minutes should be blinking. This indicates that your timer is in normal operating mode. Be sure to close and lock the enclosure when finished.

### ***V Manual Operation: How to start and stop a manual cycle.***

At times, it is necessary to run a manual cycle for your pool system, such as: when adding chemicals or to freshen up your pool after a storm. To run a cycle at any time, press the On/Off button, and an abbreviated cycle menu will appear (see image to the left).

note: The Auxiliary (Au) option is not present when the device is in fireman mode.

This menu allows you to select time durations for a custom cycle in hour increments. Use the buttons to select High(Hi) Low(Lo) and Auxiliary(Au) durations for your manual cycle. If no buttons are pressed for a few seconds, the menu will time out, and the cycle as specified on the display will begin automatically. This allows one-touch operation of a manual cycle. If the 'Enter' button is pressed at the Auxiliary cycle(Au) duration, the cycle will begin immediately. For convenience, the cycle values are stored and become the default values the next time a manual cycle is run.

**Standard mode:** Example: Hi 2 hours | Low 4 hours Auxiliary 2 hours | Current Time: 10:20 AM

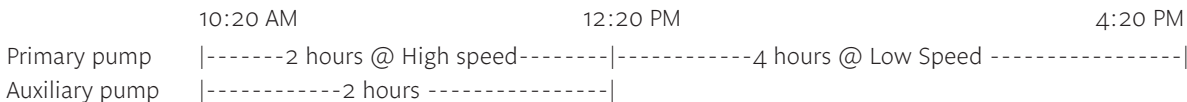

**Fireman mode:** Example: Hi 2 hours | Low 4 hours | Current Time: 10:20 AM

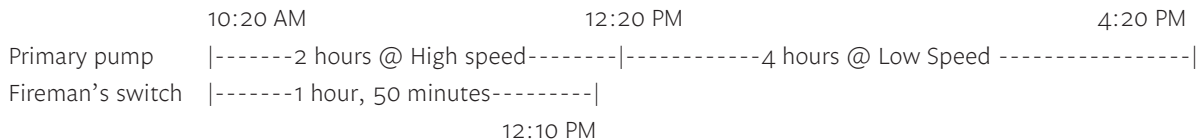

### Stopping a cycle:

If a cycle is in progress (as indicated by the animated pump icon), pressing the on/off button will stop the cycle which is currently in progress. The next cycle time will start automatically at its designated start time. The on/off button will stop the cycle whether the cycle was manual or automatic.

## VI Troubleshooting & Cleaning

Symptom	Possible Cause	Fix
Timer has no display	Contrast not adjusted	Adjust contrast with Phillips-head screwdriver.
Timer has no display	No Power*	Check circuit breaker.
Time/Date Incorrect	Dead battery	Replace 9V battery

If you want to turn your pool pump off, simply press the “On/Off” button, and it will turn off. The “On/Off” button will terminate a manual cycle, and will also terminate an automatic cycle. Be sure to close and lock the enclosure when finished.

\*Have qualified electrical technician determine why there is a loss of power.

There are no user-servicable parts inside. Refer all service inquiries to the factory.

**Cleaning:** Disconnect power at breaker. Wipe with a dry cloth only. Do not use any cleaning solutions as they may damage the display. Damage to the display is not covered by the warranty. Be sure to close and lock the enclosure when finished.

### ***VII Limited 3-Year Warranty:***

If within three (3) years from date of purchase, this product fails due to a defect in material or workmanship, Allen Concepts, Incorporated will repair or replace, at its sole option, the unit free of charge. This warranty applies only to the original purchaser and is not transferable.

The warranty does not apply to: (a) damage caused by accident, abuse, mishandling, dropping, natural disaster, or any negligent use; (b) units which have been subject to unauthorized repair, taken apart, or otherwise modified; (c) units not used in accordance with the direction; (d) damages exceeding the cost of the product. Some states do not allow a limitation of damages, so the foregoing limitation may not apply to you. This warranty gives you specific legal rights and you may have other rights that vary from state to state.

The display backlight is warranted for one year. If the backlight fails, the device will still be functional.

ALLEN CONCEPTS INCORPORATED WILL NOT BE LIABLE FOR INCIDENTAL OR CONSEQUENTIAL DAMAGES. THIS WARRANTY IS IN LIEU OF ALL OTHER EXPRESS OR IMPLIED WARRANTIES. ALL IMPLIED WARRANTIES, INCLUDING THE WARRANTY OF MERCHANTABILITY AND THE WARRANTY OF FITNESS FOR A PARTICULAR PURPOSE, ARE HEREBY MODIFIED TO EXIST ONLY AS CONTAINED IN THIS LIMITED WARRANTY, AND SHALL BE OF THE SAME DURATION AS THE WARRANTY PERIOD STATED ABOVE.

This warranty service is available by either (a) returning the product to the dealer from whom the unit was purchased, or (b) mailing postage prepaid to:

Allen Concepts, Inc. | 3165 S Alma School Rd | Suite 29-215 | Chandler, AZ 85248

Back Cover